

## BAV74LT1 SWITCHING DIODE

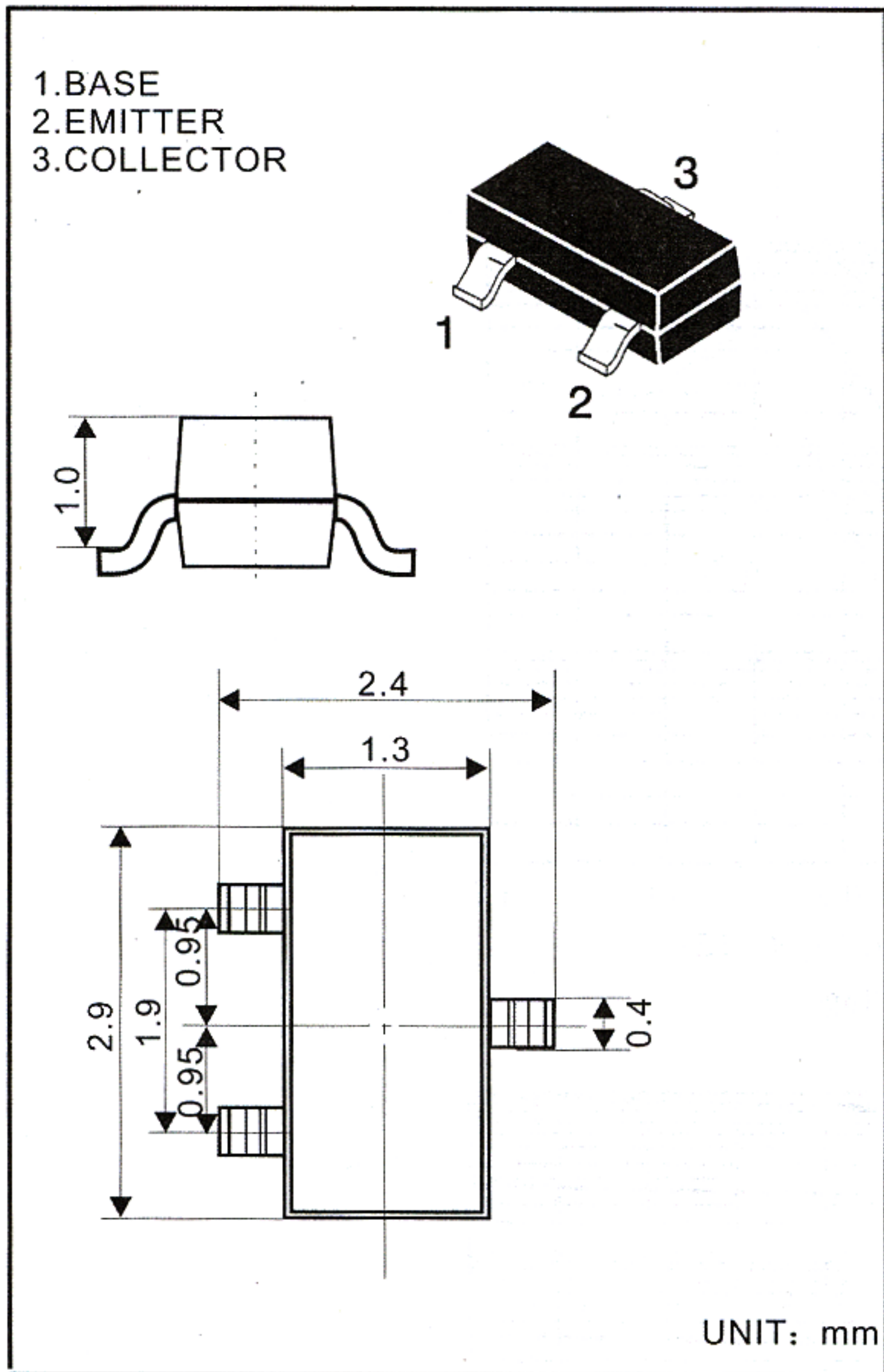

### FEATURES

**Power dissipation**

$P_D$ : 225mW ( $T_{amb}=25^\circ C$ )

**Forward current**

$I_F$ : 200mA

**Reverse voltage**

$V_R$ : 50V

**Operating and storage junction temperature range**

$T_J, T_{stg}$  :  $-55^\circ C$  to  $+150^\circ C$

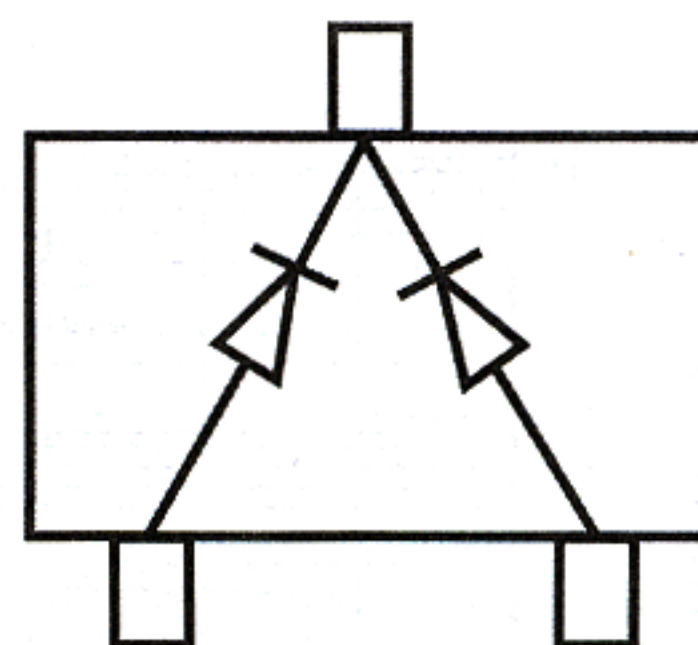

MARKING: JA

### ELECTRICAL CHARACTERISTICS

( $T_{amp}=25^\circ C$  unless otherwise specified)

Parameter	Symbol	Test conditions	MIN	MAX	UNIT
Reverse breakdown voltage	$V_{(BR)}$	$I_R=5 \mu A$	50		V
Reverse voltage leakage current	$I_R$	$V_R=50V$		0.1	$\mu A$
Forward voltage	$V_F$	$I_F=100mA$		1	V
Diode capacitance	$C_{tot}$	$V_R=0V, f=1MHz$		2	pF
Reverse recovery time	$t_{rr}$	$I_F=I_R=10mA$ $I_{rr}=0.1I_R$		4	ns

