

1SS187 SWITCHING DIODE

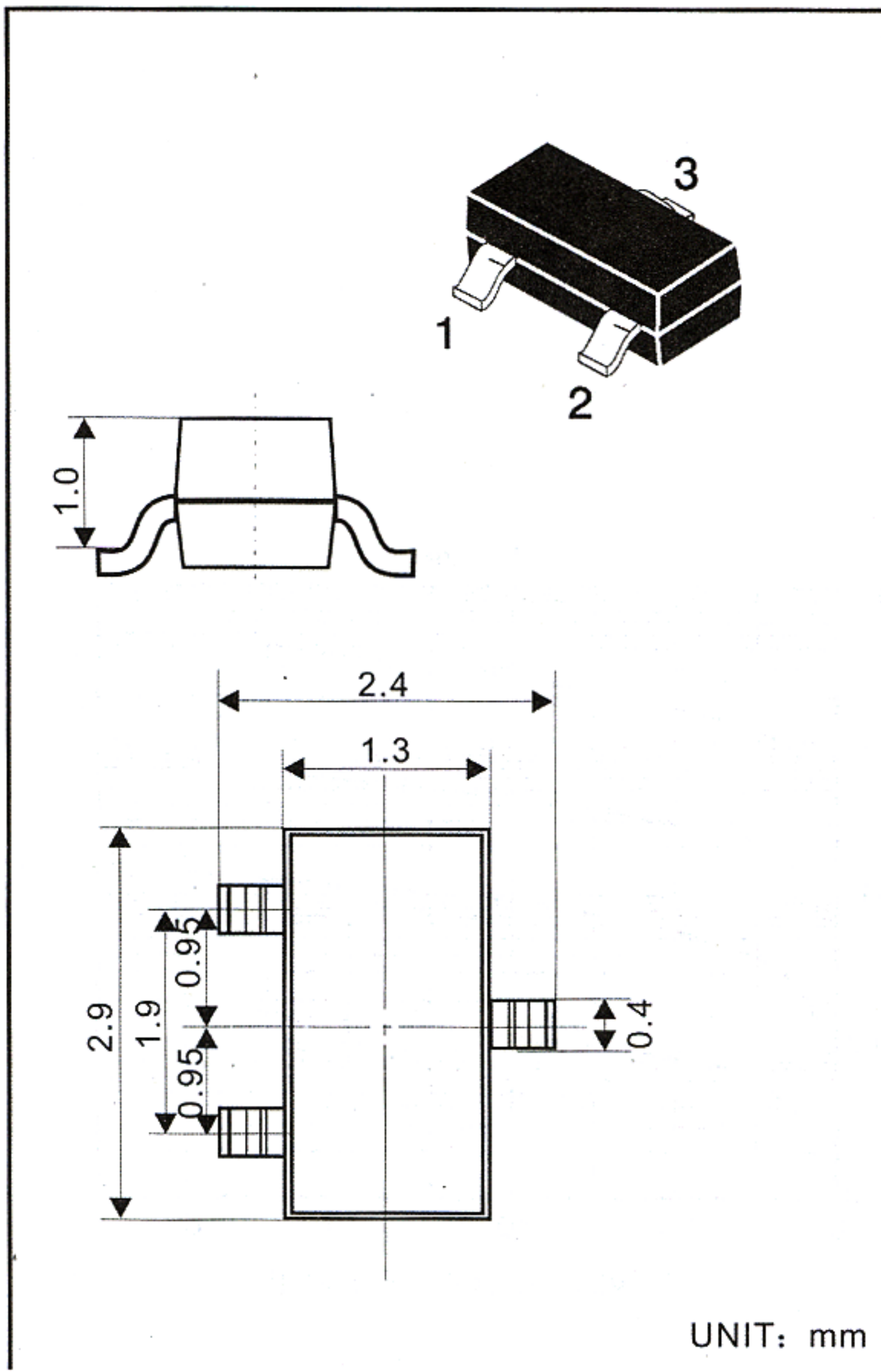

FEATURES

Power dissipation

P_D : 150mW ($T_{amb}=25^\circ\text{C}$)

Forward current

I_F : 100mA

Reverse voltage

V_R : 80V

Operating and storage junction temperature range

T_J, T_{stg} : -55°C to $+150^\circ\text{C}$

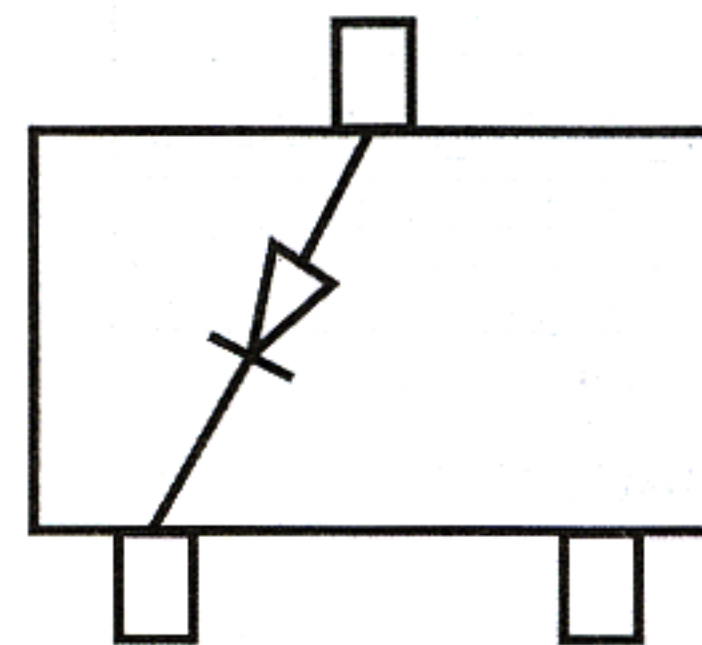

MARKING: D3

ELECTRICAL CHARACTERISTICS

($T_{amp}=25^\circ\text{C}$ unless otherwise specified)

Parameter	Symbol	Test conditions	MIN	MAX	UNIT
Reverse breakdown voltage	$V_{(BR)}$	$I_R=100\mu\text{A}$	80		V
Reverse voltage leakage current	I_R	$V_R=80\text{V}$		0.5	μA
Forward voltage	V_F	$I_F=100\text{mA}$		1.2	V
Diode capacitance	C_{tot}	$V_R=0\text{V}, f=1\text{MHz}$		4	pF
Reverse recovery time	t_{rr}	$I_F=I_R=10\text{mA}$ $I_{rr}=0.1I_R$		4	ns

