

## 1SS184 SWITCHING DIODE

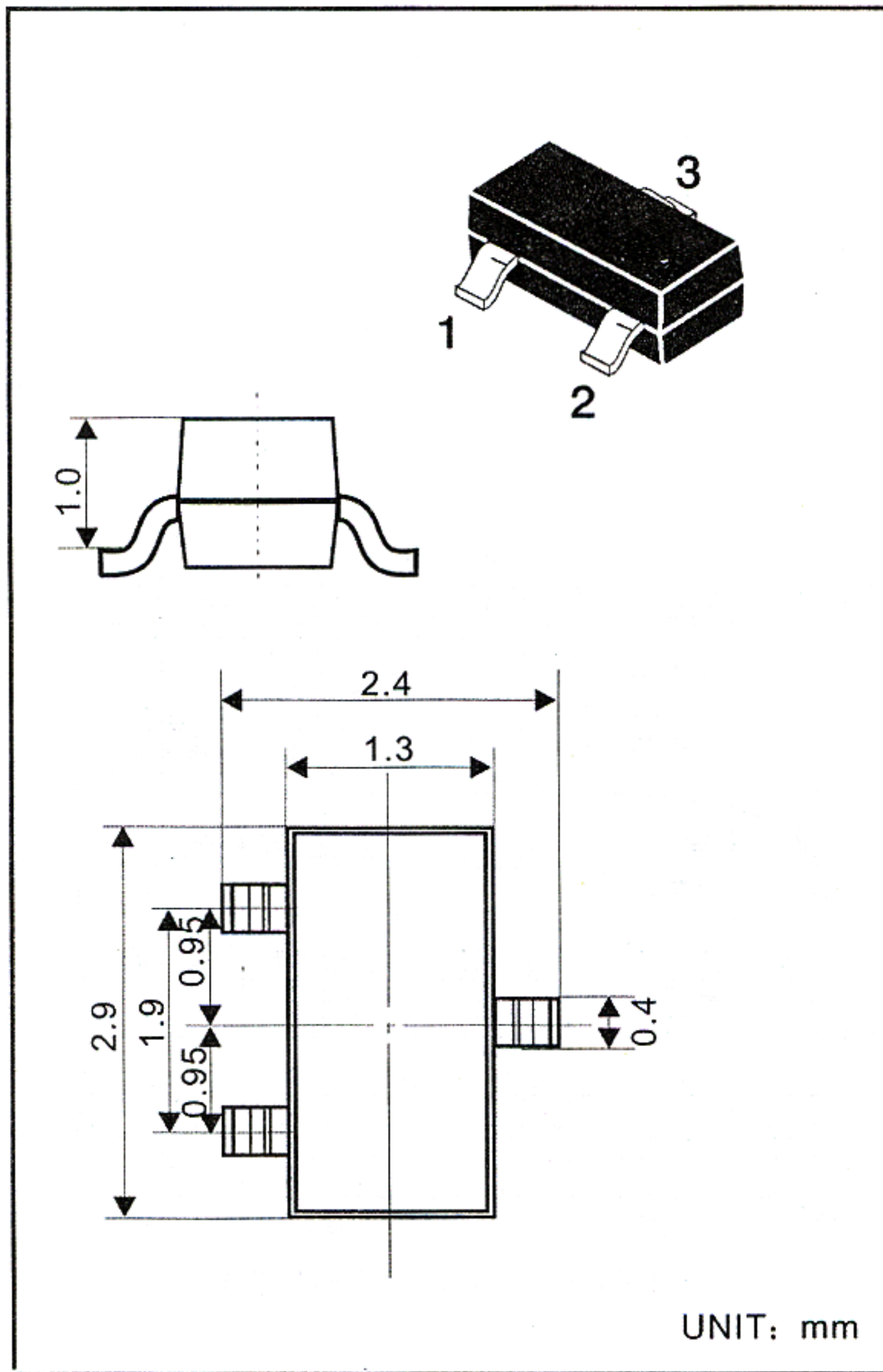

### FEATURES

#### Power dissipation

$P_D$ : 150mW ( $T_{amb}=25^\circ\text{C}$ )

#### Forward current

$I_F$ : 100mA

#### Reverse voltage

$V_R$ : 80V

#### Operating and storage junction temperature range

$T_J, T_{stg}$ :  $-55^\circ\text{C}$  to  $+150^\circ\text{C}$

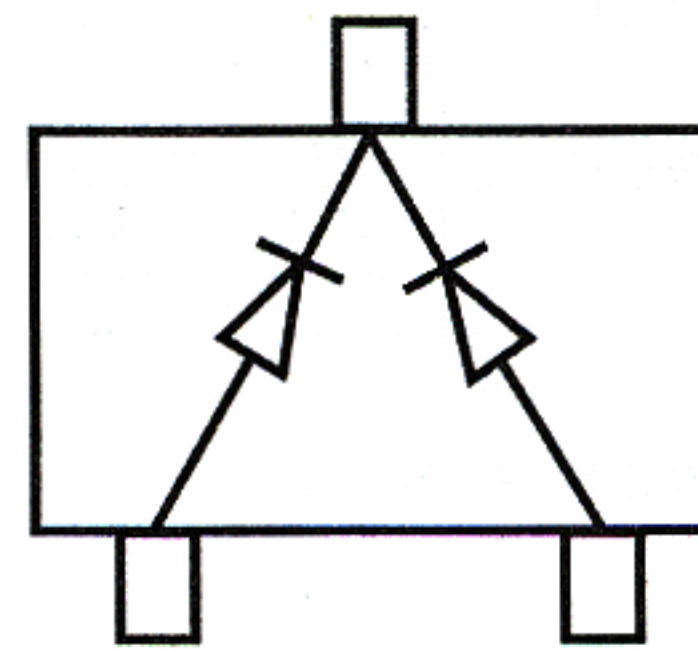

MARKING: B3

### ELECTRICAL CHARACTERISTICS

( $T_{amp}=25^\circ\text{C}$  unless otherwise specified)

Parameter	Symbol	Test conditions	MIN	MAX	UNIT
Reverse breakdown voltage	$V_{(BR)}$	$I_R=100\ \mu\text{A}$	80		V
Reverse voltage leakage current	$I_R$	$V_R=80\text{V}$		0.5	$\mu\text{A}$
Forward voltage	$V_F$	$I_F=100\text{mA}$		1.2	V
Diode capacitance	$C_{tot}$	$V_R=0\text{V}, f=1\text{MHz}$		3	pF
Reverse recovery time	$t_{rr}$	$I_F=I_R=10\text{mA}$ $I_{rr}=0.1I_R$		4	ns



